

VX1800



## NET VX Series

### VX1800 Voice Exchange™ for Unified Communications

- Intelligent media gateway for seamless migration to VoIP and unified communications
- High capacity multi-path call processing, supporting up to 1000 "any-to-any" simultaneous calls
- Reduces costs by enabling voice infrastructure consolidation, centralization, and reduction
- Supports enterprise mobility for SIP WiFi devices and fixed-mobile convergence applications, Redundant AC powered, Expandable platform with optional software and hardware modules

#### ENTERPRISE-CLASS INTEGRATION FOR UNIFIED COMMUNICATIONS

Traditional Enterprise communications are silos with multiple networks with their own dedicated platforms, protocols, and devices. Additionally, organizations may have diverse systems leading to large and complex networks.

Today, voice, video, messaging, and other web based applications are converging on a single data network. Functions such as IP Telephony, calendaring, Instant messaging, video, conferencing, wireless, rich presence, and other collaboration tools collectively called Unified Communications is helping organizations improve employee productivity.

While migrating to Unified Communications, organizations need solutions that help protect their investments, and a solution that guarantees network reliability, high-availability, branch survivability, and security.

#### FLEXIBILITY THAT DRIVES GREATER COST SAVINGS

The VX1800 provides a lower cost solution for VoIP and unified communications by enabling enterprises to consolidate or reduce existing voice network infrastructure. With support for enterprise mobility and SIP-WiFi devices, the VX1800 can also help reduce on-campus cellular service costs.

#### SECURITY WITH SCALABILITY

The VX1800's optional hardware-based Security Acceleration Module provides scalable, high-performance IPSEC, SRTP & TLS encryption for voice over IP communications. With up to 24 T1/E1 ports the VX1800 has the scalability for large enterprise sites, supporting up to 5000 users in a single-box solution with redundant and expandable software modules.

#### EXPANDABLE AND DESIGNED FOR THE FUTURE

The VX Series expandable software modules support a broad set of integrated media gateway features, including SIP trunking, IP - IP mediation, bandwidth optimization, hardware-accelerated security, and remote survivability. These advanced options enable the VX1800 to deliver what enterprises typically need for migration to IP-based voice networking, unified communications and enterprise mobility while maintaining interoperability with existing voice networks and PBX infrastructure.

#### BANDWIDTH SAVINGS

In addition to a wide range of voice compression technologies, the VX1800 uses BESTflow™ technology to enable voice calls to be carried over the WAN while utilizing less than half the bandwidth of traditional VoIP switches.

#### ABOUT NET

Network Equipment Technologies, Inc. (NET) has provided voice and data communications equipment for multi-service networks requiring high degrees of versatility, interoperability, security and performance. NET's broad family of products are purpose-built for mixed-service, multi-protocol networks; bandwidth-sensitive site communications; high performance, security-sensitive transmissions; and converged communications. The Company's NX (network exchange) and VX (voice exchange) products enable interoperability and integration with existing networks for seamless migration to secure IP-based voice and data communications.

## VX1800 BASE SPECIFICATIONS

### Interfaces

- Capacity - 6 slots for digital modules
- T1 / E1 digital modules - 1, 2, and 4 port versions, 24 port maximum per node
- Ethernet - 2 x 10/100/1000 Ethernet ports
- RS232 - Console for setup and debugging

### VoIP Signaling

- SIP - RFC3261 compliant

### TDM Signaling

- CAS: MF-R1, T1 CAS (E&M, Loopstart), E1 CAS (MFC-R2)
- ISDN: AT&T 4ESS, AT&T 5ESS, Nortel DMS-100, Euro ISDN (ETSI 300-102), QSIG, NTT InsNet(Japan), Harris 20/20, CoreNet and ANSI National ISDN-2 (NI-2)
- SS7: ISUP (ANSI88, ANSI92, ANSI95, ITU White book, ITU blue book, ITU97, Q.767, ESTlv2, ESTlv3)

### Voice Features

- Voice compression: G.711 (A-law and  $\mu$ -law), G.723 (5.3 or 6.3 Kbps), G.729A, G.729AB, G.726 (16, 24, or 32 Kbps), G.727 (16, 24, or 32 Kbps)
- Automatic call type detection/pass through for voice/modem/fax
- RFC2833 in-band DTMF signaling over RTP
- G.168 echo cancellation at 128ms tail length
- T.38 real time fax relay with CNG tone detection
- Voice activity detection, silence suppression, Automatic comfort noise generation

- Call progress tone generation and detection - Dial tone, busy, ring-back, and congestion
- RTP / RTCP

### Routing

- Dynamic flexible call routing with up to 10000 entries
- Link quality management (LQM) via ICMP or SIP-OPTIONS
- Multiple IP to IP and TDM to IP routing
- Multiple routing tables per channel, per port
- Load balancing
- DiffServ-based IP QoS support (marking, queuing and scheduling)
- 802.1p based Layer 2 QoS support
- Static IP routing
- Carrier selection via Least cost routing
- Local session control & management

### Security

- Transport Layer Security (TLS)
- Built-in VOIP aware firewall
- SSH
- Smart card authentication
- Hardened operating system
- Denial of service (DOS) attack mitigation and protection
- Advanced remote access control
- Spoofing detection and avoidance
- DNS, CLID, call type pre-authentication

### Configuration/Network Management

- SNMPv2 - traps, alarms, and statistics
- VXbuilder™ (GUI and Wizard based provisioning tool)
- VXwatch™ (real-time monitoring tool)
- Network logging (syslog)
- Active Directory User Integration

### Chassis Data

- Rack mount: 3U, 19in. (483mm) rack mountable with EIA and telco rack support
- Normal operating conditions: 32F to 104F (0C to 40C)
- Redundant AC power: 100 - 240 Volt, 50/60 Hz, 200 Watt
- Humidity: 10% to 90% non-condensing

### EMC & Safety Compliance

- Meets EN 300 386, EN55022, EN55024, EN60950, UL60950, CB

## VX1800 OPTIONAL SOFTWARE MODULES

### VoIP Signaling

- H.323v3 - Interconnection with H.323 based devices
- BESTflow - Bandwidth saving VOIP for low speed links
- SIP Trunking (ITSP) support
- IP to IP mediation
- Session Limit Controller
- SIP registrar
- SIP registrant
- SIP Proxy-like mode with survivability and local switching

### Security

- Secure RTP (SRTP) - Full capacity hardware accelerated
- IPsec
- MD5 digest authentication

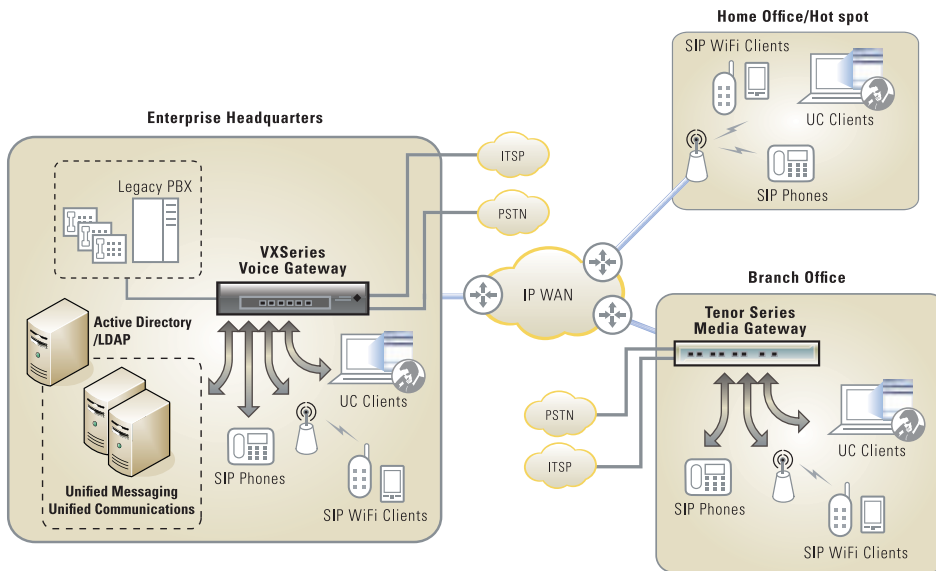

**Microsoft**  
**GOLD CERTIFIED**  
 Partner

OEM Hardware Solutions  
 Information Worker Solutions  
 Networking Infrastructure Solutions

**ENTERPRISE-CLASS INTEGRATION OF UNIFIED COMMUNICATIONS WITH TELECOM INFRASTRUCTURE:** NET's VX Series and Tenor Series Media Gateways provide full connectivity between Unified Communications and Telecom infrastructure. NET's portfolio meets the Media Gateway requirements for UC deployments for large to small enterprises for their headquarters and branch office locations.

**WEBSITE:** Please visit our website at [www.net.com](http://www.net.com) for information on how to contact us, place an order or get more information on NET solutions.

**net**  
 Network Equipment Technologies

**Corporate Headquarters**  
 6900 Paseo Padre Parkway  
 Fremont, CA 94555 U.S.A.  
 T 510.713.7300  
 F 510.574.4000  
 E info@net.com

**N.E.T. Federal**  
 21660 Ridgetop Circle,  
 Suite 100Dulles, VA 20166, U.S.A  
 T 703.948.1800  
 F 703.948.1850  
 E net\_federal@net.com

This document does not create any express or implied warranty by NET about its products or services, or the features thereof, and NET makes no representation regarding the suitability of its products for any particular purpose. Specifications and other information herein is subject to change without notice.  
 © 2008 Network Equipment Technologies, Inc. All rights reserved. VX, Tenor series, VXbill, VXbuilder, VXgate, VXscript, VXvue, VXwatch, NET, and the NET logo are trademarks of Network Equipment Technologies, Inc., and its subsidiary, N.E.T. Federal, Inc. All other trademarks are the sole property of their respective companies.